

TEKTRONIX®

**1501
TIME DOMAIN
REFLECTOMETER**

OPERATORS MANUAL

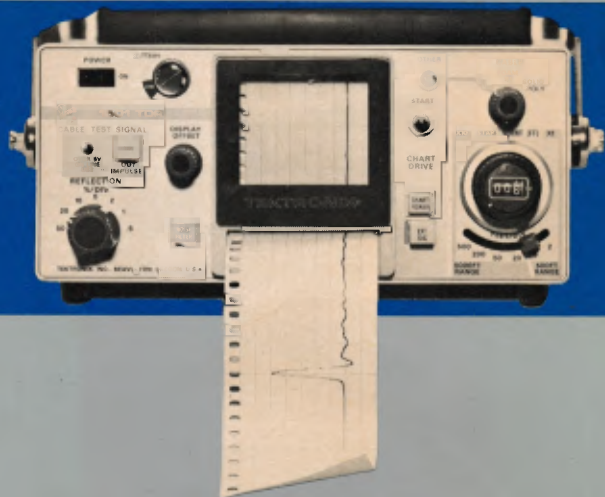

TABLE OF CONTENTS

GENERAL

The 1501: What it is and What it Does	2
What is TDR	3

BASIC OPERATION (and First-Time Operating Procedure)

Equipment	4
Connecting the 1501 to an Oscilloscope	5
Powering the 1501	6
Connecting the Cable to be Tested to the 1501	8
Initial Control Settings	10
Test Signals	12
Locating a Discontinuity in a Cable	14
Evaluating a Discontinuity	16
Noise Filter	17

Making a Graph	18
Removing the Cover	20
Removing the Power Pack	21
Converting the Power Pack from 115 V to 230 V	22
Battery Care	23
Installing Chart Recorder Paper	24
Recording from an External Source	25

MEASUREMENT CONCEPTS	26
----------------------	----

SPECIFICATION	31
---------------	----

APPENDIX

Connecting the 1501 to Other Oscilloscopes	36
--	----

WARRANTY

All TEKTRONIX instruments are warranted against defective materials and workmanship for one year. Any questions with respect to the warranty should be taken up with your TEKTRONIX Field Engineer or representative.

All requests for repairs and replacement parts should be directed to the TEKTRONIX Field Office or representative in your area. This will assure you the fastest possible service. Please include the instrument Type Number or Part Number and Serial Number with all requests for parts or service.

Specifications and price change privileges reserved.

Copyright © 1972 by Tektronix, Inc., Beaverton, Oregon. Printed in the United States of America. All rights reserved. Contents of this publication may not be reproduced in any form without permission of Tektronix, Inc.

U.S.A. and foreign TEKTRONIX products covered by U.S. and foreign patents and/or patents pending.

TEKTRONIX is a registered trademark of Tektronix, Inc.

Tektronix, Inc. ● P. O. Box 500 ● Beaverton, Oregon 97005 ● Phone 644-0161 ● Cables: Tektronix

The 1501:

what it is and what it does

The 1501 is a portable, battery-powered Time Domain Reflectometer. Its primary use is to locate and evaluate faults in electrical transmission lines. Faults can be located in cables up to 10,000 feet long (3000 meters for the metric version). A plug-in strip-chart recorder makes graphs of the TDR signals obtained from testing a cable. These graphs provide a "finger print" of the electrical characteristics of the cable under test. If a fault is detected, the graph can be used to evaluate it. If the cable is found to be good, the graph can be saved and compared with graphs obtained from future tests. The 1501 can also be connected to an oscilloscope to provide CRT monitoring of TDR signals.



What is TDR

Time Domain Reflectometry is pulse-echo testing of transmission lines. This cable testing method is sometimes referred to as "radar testing". Using pulse-echo testing, a pulse (called the incident pulse) is applied to the beginning of a cable. The pulse travels through the cable until it reaches an impedance discontinuity (i.e., a change in impedance due to a break, a short, a termination, etc.). At the discontinuity, a portion of the pulse is reflected back to the beginning of the cable. The rate of travel (propagation velocity) of a pulse through a cable is constant for a particular kind of cable. The distance from the beginning of the cable to the discontinuity can, therefore, be calculated by measuring the time between the start of the incident pulse and the return of the reflected pulse. The nature of the discontinuity can be determined by comparing the amplitude of the incident pulse with that of the reflected pulse. The 1501 provides a pulse source (or test signal) and a method of measuring both the time and the amplitude relationships between incident and reflected pulses.

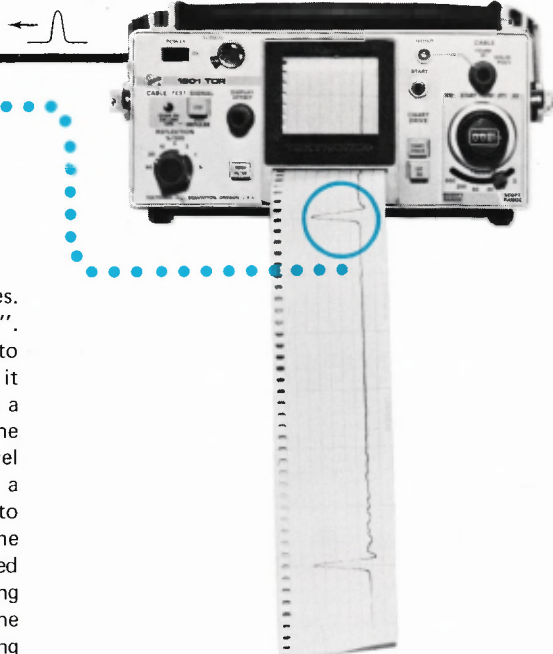

BASIC OPERATION

The following section provides a familiarization procedure combined with a discussion of the 1501 operation. The familiarization procedure is in bold type and can be followed without reading the accompanying operation discussion. This procedure can also be used for incoming inspection.

Equipment

1. Obtain the following equipment for use in the familiarization procedure:

a. An oscilloscope that has a vertical input with a 200 mV/division deflection factor and an external horizontal input with a 500 mV/division deflection factor. A TEKTRONIX Type 323 or 324 Oscilloscope is suggested. See the instructions on page 36 for connecting the 1501 to other TEKTRONIX oscilloscopes.*

b. 10 to 50 feet (2 to 15 meters) of 50 Ω or 75 Ω coaxial cable.



*A 1501 can be used without an oscilloscope, but an oscilloscope aids in familiarizing an operator with 1501 operation.

Connecting the 1501 to an Oscilloscope

2. Connect a cable between the 1501 HORIZ OUT connector and the oscilloscope external horizontal input connector; connect another cable between the 1501 VERT OUT connector and the oscilloscope vertical input connector.

Although the standard 1501 comes with a plug-in chart recorder, it is sometimes desirable to monitor a TDR test on an oscilloscope CRT, before making a graph with the chart recorder. The HORIZ OUT and VERT OUT connectors provide the horizontal and vertical signals from the 1501 for display on the oscilloscope CRT. Any oscilloscope which meets the previously mentioned requirements can be used to monitor the 1501 output signals. The TEKTRONIX Type 323 and 324 oscilloscopes make convenient monitors since they are both portable, battery-powered instruments that have the same physical dimensions as the 1501. The TEKTRONIX 211 miniscope also makes a convenient monitor for the 1501*. A Handle Conversion Kit (for two

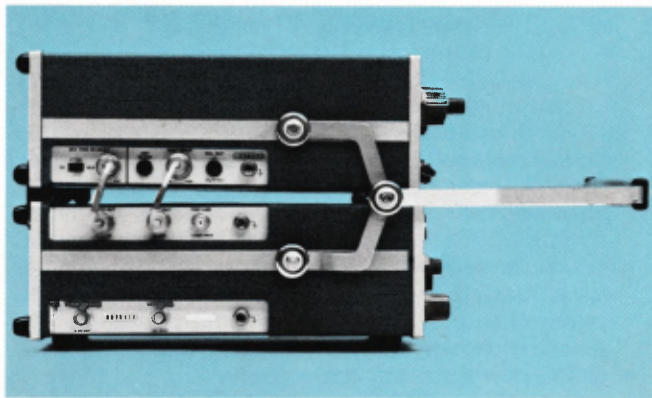

instruments), TEKTRONIX Part No. 040-0563-00, allows a 1501 to be physically connected to either a Type 323 or 324 to make a unitized, TDR/monitor package.

*A BNC-to-probe adapter is available from TEKTRONIX (Part No. 013-0084-01) for connecting the 211 probe to the 1501 VERT OUT connector.

Powering the 1501

3. Set the 1501 power pack switch for the power source to be used, external DC, AC, or internal batteries. If AC power is to be applied, also set the switch for the desired charge rate, TRICKLE CHG or FULL CHG. (Any time AC power is applied to the power pack, the power pack batteries charge.) A small screwdriver is required to move the switch. If AC or external DC power is chosen, connect the 1501 to a suitable AC or DC power source, respectively.

NOTE

The batteries in the power pack of an instrument just received from the factory should be fully charged before use. The instrument can be operated from either AC or external DC power while the batteries are charging. See page 23 for charging instructions.

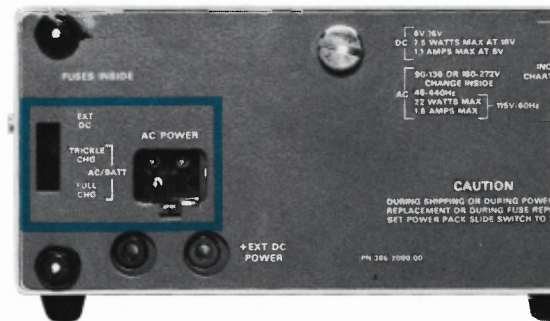

Power is applied to the 1501 circuitry through the removable power pack. The power pack contains rechargeable batteries, a battery charging circuit and connectors for connecting external AC or DC power sources. The charging circuit allows the power pack batteries to be charged using AC line voltage.

Since the power pack can be removed and its batteries recharged independent of the 1501, continuous power pack battery operation of the 1501 is possible if a second power pack is purchased. Instructions for removing and replacing the power pack are given on page 21.

For power pack battery operation, the power pack switch may be set to either of its two AC/BATT positions. When fully charged, the power pack batteries should power the 1501 for 8 hours or more and make at least 30 charts. When the 1501 POWER switch is set to ON, the BATTERY meter on the front panel indicates the charge on the batteries. To avoid damage to the battery cells, power pack battery operation of the 1501 should not be continued for long periods after the meter begins reading LOW, especially if charts are being made.

For AC power operation, set the power pack control switch to one of its two charge positions and connect the power cord to a suitable AC power source. Under AC operation, the power pack batteries are charged while power is being applied to the 1501 circuitry. Thus, if the power pack batteries are fully charged, set the power pack switch to TRICKLE CHG, and if the charge on the batteries is low, set the switch to FULL CHG. If AC power is connected to the power pack when the power pack switch is set to EXT DC, the power pack batteries will charge at the full charge rate, but the 1501 circuitry will receive its power from the external DC source. The power pack can be powered with either 115 V or 230 V nominal AC line voltage. See page 22 for instructions for converting the power pack from one line voltage to the other.

For external DC power operation, set the power pack switch to EXT DC and apply DC power to the EXT DC POWER connectors (observe polarity markings). DC voltages from +6 volts to +16 volts can be used to power the 1501. An automobile battery is a good external DC voltage source. The power pack batteries can not be charged using external DC power.

Connecting the Cable to be Tested to the 1501

4. With the 1501 POWER switch set to OFF, remove the chart recorder from the 1501 and set the 50 Ω -75 Ω switch for the impedance of the cable to be tested in this procedure. The 50 Ω -75 Ω switch is a slide switch which is located on the circuit board on the left side of the chart recorder compartment. Slide the switch toward the front of the instrument for 50 Ω cables and toward the rear for 75 Ω cables.

5. Connect the cable to be tested in this procedure to the TEST LINE connector. Do not terminate the open end of the cable.



Using the 1501, discontinuities can be located in cables of any impedance. The instrument is calibrated, however, to accurately evaluate these discontinuities, only in 50 Ω or 75 Ω cables. The 50 Ω -75 Ω switch determines which cable impedance the 1501 is set for. The following section on TDR measurements discusses a method of modifying the 1501 or of making calculations so that discontinuities in cables of other impedances can be measured.

The TEST LINE connector is a Type F female connector. A Type F male-to-BNC female connector adapter is included with the 1501 so that cables with BNC connectors can be tested. Table 1 shows some optional connector adapters that are available from TEKTRONIX. These adapters allow connections to be made to cables with other kinds of connectors.

A Type F male-to-F male adapter and a Type F female-to-F female adapter are also included with the 1501. They can be used to extend cables.

TABLE 1
Optional Connector Adapters for the 1501

Type	TEKTRONIX Part No.
BNC Male-to-GR	017-0064-00
BNC Male-to-N Female	017-0058-00
BNC Male-to-UHF Female	017-0032-00
BNC Male-to-Dual Binding Post	103-0035-00
BNC Female-to-Clip Leads	013-0076-00
F Female-to-GR	017-0089-00
Banana-to-clip Patch Cords	
Red	012-0015-00
Black	012-0014-00

Initial Control Settings

6. Set the power switches on both the 1501 and oscilloscope to ON and set their controls as follows:

1501

STEP-IMPULSE	Pushbutton In
DISPLAY OFFSET	As Is
REFLECTION %/DIV	20
NOISE FILTER	Pushbutton Out
STYLUS POSITION	As Is
CABLE	SOLID POLY
START POINT	000
RANGE	2 FT (.5 M)
CHART POWER	Pushbutton Out
EXT DRIVE	Pushbutton Out

Oscilloscope

Volts/Div	.2 (Cal)
Input Coupling	Gnd
Vert. Position	Centered, Pull-Switch In
Horiz. Position	Centered, Pull-Switch Out
Time/Div	Ext. Horiz, Cal
Trigger Level	Centered
Trigger Source	Ext. Trig. or Horiz, DC
Ext. Trig. or Horiz. Atten.	10X

7. With the oscilloscope input coupling switch set to ground, adjust the Time/Div Variable so that the trace on the CRT is 10 divisions long.* Then adjust the vertical and horizontal position controls so that the trace is vertically centered and starts on the left edge of the graticule. Set the oscilloscope input coupling switch to DC and adjust the 1501 DISPLAY OFFSET control to vertically center the display on the CRT.

*With the Type 323 or 324 set for a 10X horizontal magnification and a 10X external horizontal input attenuation, the horizontal deflection factor can be set to 500 mV/division using the Time/Div Variable control.

The DISPLAY OFFSET control adjusts the level of the vertical signal that is applied to the oscilloscope or to the chart recorder. The oscilloscope vertical position control controls the vertical position of the display on the CRT; the chart recorder STYLUS POSITION screwdriver adjustment controls the vertical position of the display on the paper graph. In most cases, the oscilloscope vertical position control or the chart recorder STYLUS POSITION adjustment are preset (see steps 7 or 14, respectively) and the DISPLAY OFFSET control is used for display positioning.

Test Signals

8. Note the test signal (incident signal) displayed on the CRT and release the STEP-IMPULSE pushbutton. (For test cables shorter than 20 feet (5 meters), the reflected signal may also be visible.)

The 1501 provides a choice of two test signals, an impulse and a step. The STEP-IMPULSE pushbutton determines the type of test signal applied to the cable under test. With the pushbutton in, a 1 volt step is applied to the cable; with the pushbutton out, a 10 volt, 1.3 ns wide impulse is applied to the cable. The step signal is used whenever an accurate measurement of the impedance of the cable is desired. The impulse signal is used whenever there is a DC voltage on the cable under test of more than 5 V, as

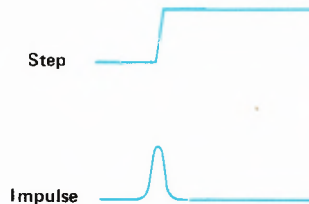
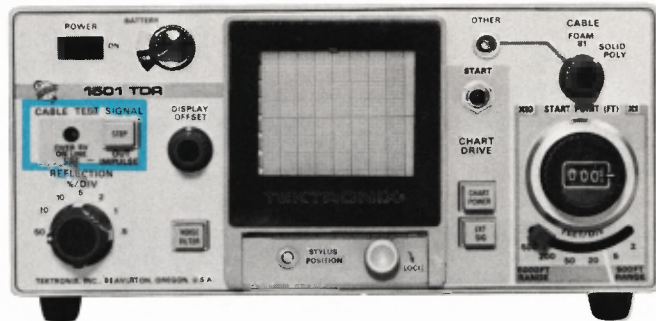

indicated by the flashing OVER 5 V ON LINE light. When this light comes on, a capacitor is switched into the test circuit to isolate the 1501 from the voltage on the cable. This capacitor will pass the impulse test signal but not the step signal. Also, the impulse test signal is more useful when testing cables that have signals on them. The step and the impulse test signals are equally useful for locating discontinuities in a cable under test.

NOTE

The impulse signal, due to its 1.3 ns width, may not be visible for the higher settings of the RANGE switch. In such cases, press the NOISE FILTER pushbutton. Also, low quality cables may greatly attenuate the reflected impulse. To display the reflected impulse in these cases, the REFLECTION %/DIV switch must be set to a higher sensitivity position.

CAUTION

Cables with DC voltages of over 100 V on them should not be connected directly to the 1501. Cables with over 100 V on them can be tested, however, if series capacitance is added between the cable and the 1501.

Locating a Discontinuity in a Cable

9. Set the RANGE switch so that the horizontal width of the CRT display window is longer than the cable under test. For example, if the cable is 30 feet (10 meters) long, set the RANGE switch to 5 FEET/DIV (2 METERS/DIV), for a display window width of 50 feet (20 meters). This setting of the RANGE switch assures that the reflected signal will appear in the display window. Measure the distance on the CRT graticule between the incident impulse rise and the reflected impulse rise. This value multiplied by the setting of the RANGE switch is the distance from the 1501 to a discontinuity in the cable under test, in this case the open end of the cable.

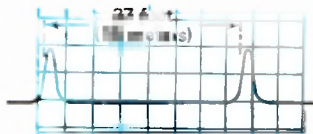

RANGE switch set to
5 feet/division
(2 meters/division)

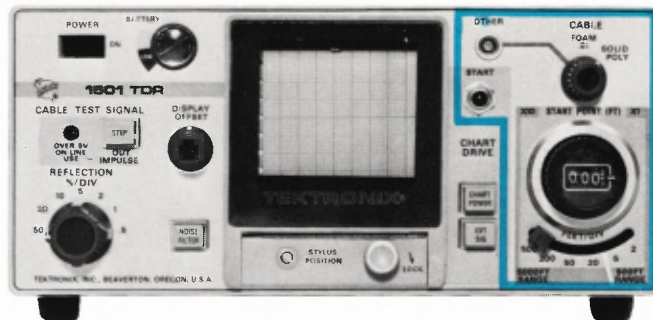

10. To more accurately locate the discontinuity, set the RANGE switch to a lower setting. (The reflected impulse does not need to be in the display window.) Using the oscilloscope horizontal position control, position the incident impulse rise to the left edge of the CRT graticule. (Be sure the START POINT control is set to 000.) Now turn the START POINT control clockwise until the reflected impulse rise is on the left edge of the graticule, and note the reading on the START POINT control. This reading is the distance from the 1501 out to the end of the cable (to the discontinuity). If the RANGE switch is set in the 20 to 500 FEET/DIV (5 to 200 METERS/DIV) range, multiply the setting of the START POINT control by 10, as indicated on the 1501 front panel.

11. Set the CABLE switch to OTHER. Using a ruler or tape measure, measure the length of the cable under test as accurately as possible. Turn the START POINT control counterclockwise to 000 and check that the incident impulse rise is on the left edge of the graticule. Then set the START POINT control for the measured length of the cable (be sure to multiply the control setting by 10 if the RANGE switch is in the X10 range). Now adjust the OTHER adjustment until the reflected impulse rise is on the left edge of the graticule. Repeat this step once or twice to account for movement of the incident impulse when the OTHER adjustment is adjusted.

The RANGE switch determines the horizontal scale of a graph or of the oscilloscope CRT graticule. The START POINT control provides calibrated horizontal display offset. The START POINT control indicates the distance from the 1501 to the point on the cable where the display window begins. The control has two ranges, 500 feet and 5,000 feet (100 meters and 1000 meters). Using the full range of the START POINT control and the highest setting of the RANGE switch, discontinuities can be located up to 10,000 feet (3000 meters) from the 1501.

The CABLE switch allows the 1501 to accurately locate discontinuities in cables of various propagation velocities. The SOLID POLY or FOAM .81 positions set the instrument to check cables with solid polyethylene or foam (propagation constant 0.81) dielectrics. These are commonly used cables. The OTHER position of the switch allows the 1501 to be adjusted to check a cable with any propagation velocity.

Evaluating a Discontinuity

12. Press the STEP-IMPULSE pushbutton and set the RANGE and START POINT controls so that both the incident and reflected steps are in the display window. Measure the amplitudes of the incident and reflected steps (use the DISPLAY OFFSET control to position the steps for measurement). The amplitude of the incident step should be 100% and the amplitude of the reflected step should be 100% above the top of the incident step.

*This ratio measurement corresponds to the commonly used TDR parameter ρ (see Chapter 3 of the TEKTRONIX Measurement Concepts book titled TIME-DOMAIN REFLECTOMETRY MEASUREMENTS).

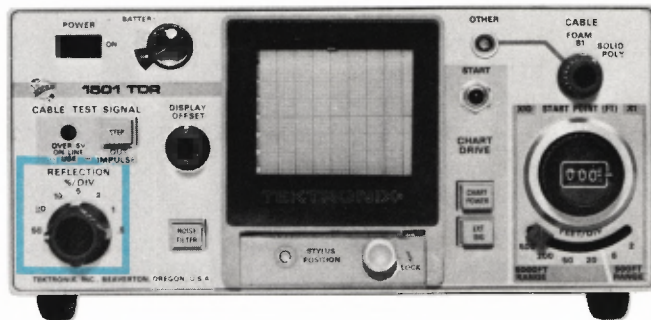

The REFLECTION %/DIV switch determines the vertical scale of the display (on a graph or on an oscilloscope CRT). The switch is calibrated to measure the ratio of the reflected signal amplitude to the incident signal amplitude* in percent. For example, if the reflected signal amplitude is half of the incident signal amplitude, the reflected signal amplitude will measure 50%. The incident signal amplitude will always measure 100% for 50 Ω or 75 Ω cables (providing the 50 Ω -75 Ω switch is properly set).

Noise Filter

13. Release the STEP-IMPULSE pushbutton and set the REFLECTION %/DIV switch to 2. Press the NOISE FILTER pushbutton and note that the displayed noise is reduced. Also note that the sweep rate is reduced.

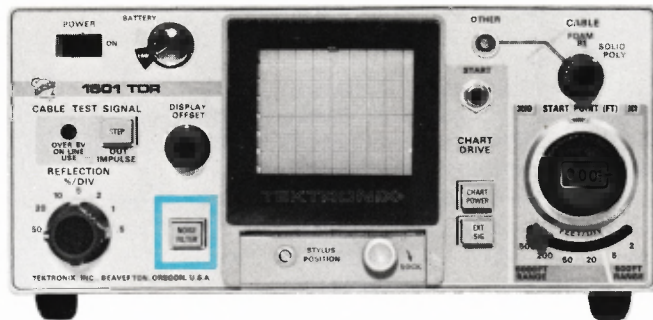

Pressing the NOISE FILTER pushbutton, reduces noise on the CRT display. The reduction in noise is accompanied by a slowing down of the sweep rate. The 1501 is automatically set in the noise filter mode when a chart is being made.

Making a Graph

14. Release the NOISE FILTER pushbutton, press the STEP-IMPULSE pushbutton and set the REFLECTION %/DIV switch to 50. Using the DISPLAY OFFSET control, center the display on the CRT graticule, then press the CHART POWER pushbutton. Note that the oscilloscope sweep is held off. Now press the START pushbutton to initiate the making of a graph. (B050252-up) Hold the START pushbutton in for a few seconds to preheat the stylus; the graph does not start until the pushbutton is released. As the graph is being made, compare the level of the display on the CRT with the level of the line being traced on the graph. Adjust the STYLUS POSITION screwdriver adjustment if needed, so that the display on the graph is at the same level as the display on the CRT graticule. When the graph is completed, tear it off and release the CHART POWER pushbutton to return the 1501 to sweep operation.

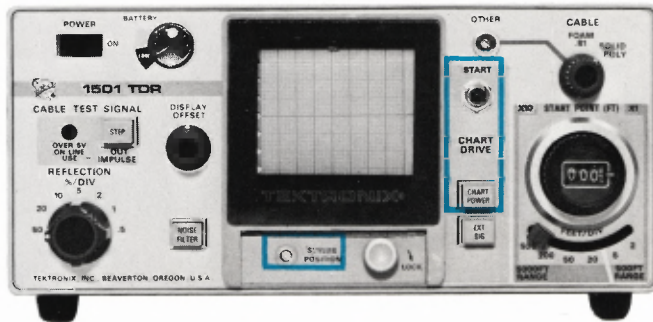

In examining the graph, note the start and stop points of the display. The display should start and stop on one of the heavy green lines on the chart paper. If the display does not start and stop in the right place, see page 24 for graph paper alignment instructions.

The chart recorder is a self-contained unit that records signals on heat sensitive paper using a hot stylus. It is installed in the 1501 and secured by the LOCK knob.

When the CHART POWER pushbutton is pressed, power is applied to the chart recorder and the sweep ramp is held off. (B050252-up) When the START button is pressed, the stylus begins heating; when the button is released, the sweep ramp starts and the graph is started. (B010100–B050251) the graph starts as soon as the START button is pressed; there is no stylus preheat time.

The chart recorder STYLUS POSITION screwdriver adjustment performs the same function as the vertical position control on an oscilloscope. The most convenient method of setting this adjustment is with an oscilloscope as illustrated in step 14. Once the STYLUS POSITION adjustment has been set, it should not require further adjustment.

When the CHART POWER pushbutton is in, but the START pushbutton has not been pressed, the stylus indicates the level of the signal at the beginning of the display window. This fact can be verified by turning the START POINT control clockwise and noting the movement

of the stylus. This feature may be helpful when the 1501 is being used without an oscilloscope. In such cases, the START POINT control can be used to locate a discontinuity without making a graph. Once a discontinuity has been located, a graph can be made with the RANGE switch set to a higher resolution position.

In evaluating a graph, the distance between two heavy green horizontal lines corresponds to one vertical division with respect to the REFLECTION %/DIV switch; the distance between two heavy green vertical lines corresponds to one horizontal division with respect to the RANGE switch.

The chart recorder can be stopped in the middle of making a graph by releasing the CHART POWER pushbutton. If this is done, however, the next graph may not start on a major division line of the graph paper.

When using internal battery power, the chart recorder can make at least 30 graphs on one charge of the batteries. To help conserve battery energy, release the CHART POWER pushbutton as soon as a graph is completed. Also, the chart recorder consumes less power when the stylus remains near the center of the paper. Tests made using the impulse mode, therefore, require less power.

Removing the Cover

1. Set the power pack switch to EXT DC.
2. Loosen the dust cover securing screw.
3. Pull the cover and the 1501 apart.
4. When replacing the cover, be careful not to pinch any of the circuit board interconnection wires.

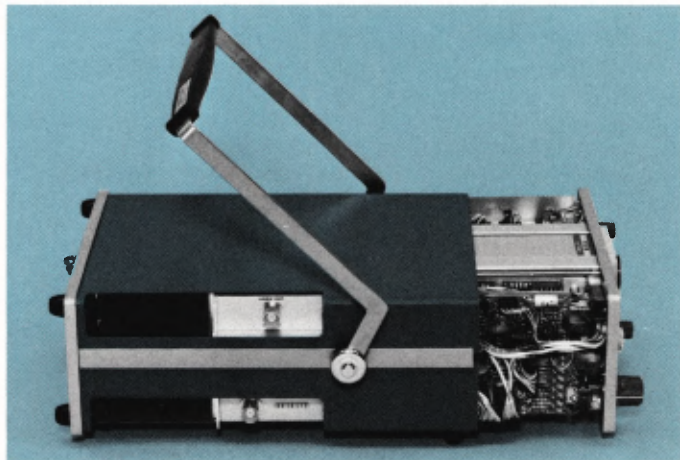

Removing the Power Pack

1. Set the power pack switch to EXT DC.
2. Release the securing clamp and pull the power pack away from its mounting area.
3. Disconnect the three power leads (green, black and white) which connect the power pack to the 1501.
4. Remove the power pack from the 1501. Avoid bumping the transformer wires or circuit board against the 1501 chassis.

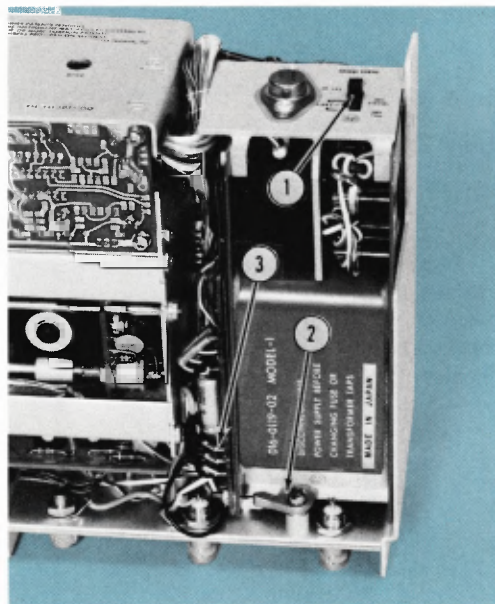

Converting the Power Pack from 115V to 230V

Disconnect the AC-leads from the pins marked 115 V and connect them to the pins marked 230 V. The power pack is shipped with insulation on the 230 V pins. Put this insulation on the 115 V pins.

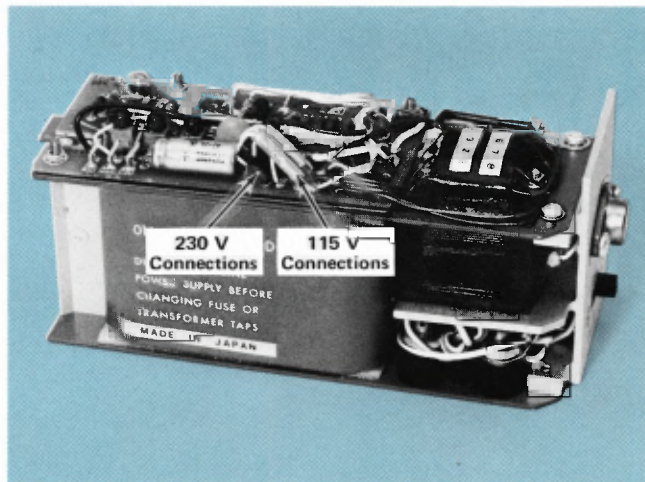

Battery Care

To charge the batteries, connect the power pack to a suitable AC power source and set the control switch to FULL CHG. Charge time for a full charge is from 15 to 16 hours. Charging the batteries at the full charge rate beyond this time causes the batteries to overcharge. The batteries can be overcharged for up to 24 hours without damaging the individual cells.

Once the batteries have received a full charge, set the power pack switch to TRICKLE CHG. With the switch in this position, enough charging current is supplied to the batteries to make up for self-discharge of the batteries, thus maintaining the batteries at full charge.

Reverse charging a power pack battery can damage it. The battery charging circuit in the power pack is designed to prevent accidental reverse charging. Reverse charging can occur, however, if the charges on the individual cells become unbalanced. Charge unbalance can develop due to cell aging, partial charging, or if a cell is replaced. If the charge unbalance becomes great enough, it is possible for the weakest cells to completely lose their charge and

become reverse charged by the current from the stronger cells.

To avoid reverse charging, the full charge cycle should be completed in preference to a partial charge cycle whenever possible. In addition, approximately once a month or every 15 charge-discharge cycles (whichever occurs first) the batteries should be charged at the full charge rate for approximately 24 hours.

Although partial recharging of the cells is not recommended as a common practice, occasional partial recharges can be tolerated. About 25 to 30 minutes of operating time can be expected from a one hour charge period.

The power pack may be stored at a temperature between -40°C and $+50^{\circ}\text{C}$ with the battery cells either fully or partially charged. The self-discharge rate of the cells increases with increased temperature. A fully charged battery will lose about 50% of its charge at room temperature in about 3 to 4 months. The battery pack should be recharged, therefore, if it has been stored without power applied to its charging circuit for a month or more.

Installing Chart Recorder Paper

About 60 graphs can be made with one roll of chart recorder paper. Use the following procedure to install a roll of graph paper in the recorder:

1. Remove the chart recorder from the 1501, lift the recorder bezel and remove the empty graph paper spool.
2. Put the new roll of graph paper in the top of the recorder and push it in place between the spring loaded paper holders. Be sure the grid on the paper is facing up.
3. Pull the paper over the rollers and down the front of the recorder, then lower the bezel. With the bezel almost in place, adjust the paper so that one of the heavy green lines is superimposed over the red line on the plate behind the paper. The line is visible through the sprocket holes on the edge of the paper.
4. When the graph paper is properly aligned, lower the bezel and install the recorder in the 1501.

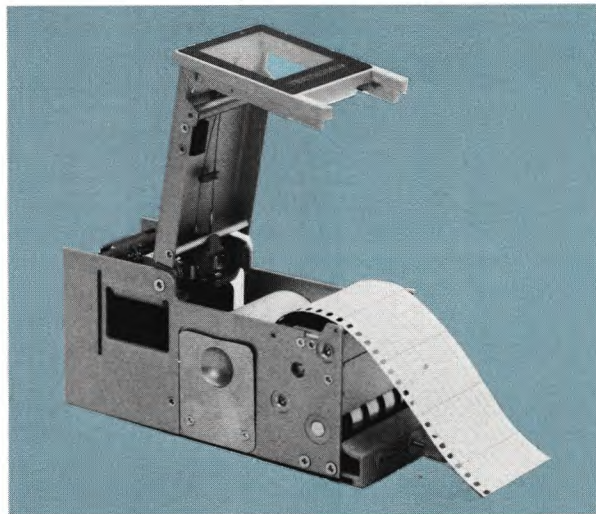

Recording from an External Source

The chart recorder can also record signals from external sources such as a TEKTRONIX 1401A Spectrum Analyzer. The signal to be recorded is applied to the 1501 through the EXT VERT INPUT connector on the 1501. At the same time, the 1501 sweep ramp must be connected through the SWEEP OUT connector to the horizontal input to the external instrument. When the EXT SIG pushbutton on the 1501 is pressed, the signal from the external source is applied to the chart recorder to be recorded on a graph. The vertical deflection factor of the chart recorder is 200 mV/division. If the 1501 is connected to an oscilloscope, the oscilloscope will also monitor the external signal when the EXT SIG pushbutton is pressed.

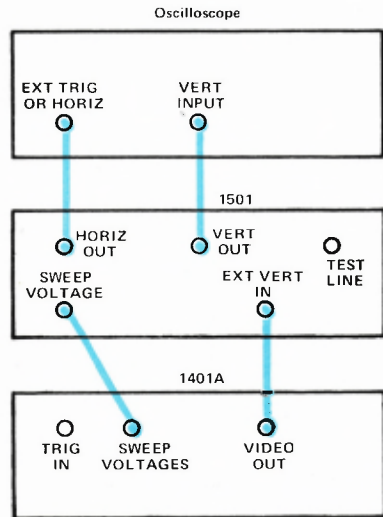

MEASUREMENT CONCEPTS

The measurement of the reflected pulse amplitude, described on page 16, can be used to determine the impedance of the discontinuity. The following illustrations show the relationship between amplitude of the reflected step or impulse and the impedance of the discontinuity.

Note that no reflection is obtained from a cable with no discontinuities if the cable is terminated with its characteristic impedance (for example, a $50\ \Omega$ cable terminated with $50\ \Omega$). If a cable has an open circuit, i.e., a break ($\infty\ \Omega$), the reflected step or impulse is +100%; and if a cable has a

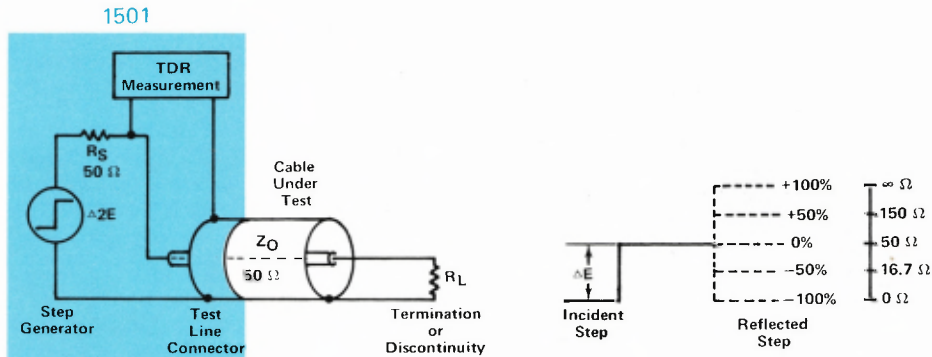

short ($0\ \Omega$), the pulse amplitude is -100% . See page 28 for more accurate charts for converting reflected pulse amplitude to impedance.

The $50\ \Omega$ - $75\ \Omega$ switch discussed on page 9 allows the source impedance of the 1501 to be changed from $50\ \Omega$ to

$75\ \Omega$ so that discontinuities can be accurately measured in cables with characteristic impedances of either $50\ \Omega$ or $75\ \Omega$. The two illustrations give measurement examples for both a $50\ \Omega$ cable and a $75\ \Omega$ cable. The magnitude of a discontinuity can only be approximated when using the 1501 to check cables with other characteristic impedances.

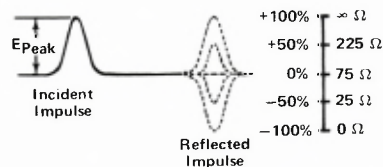
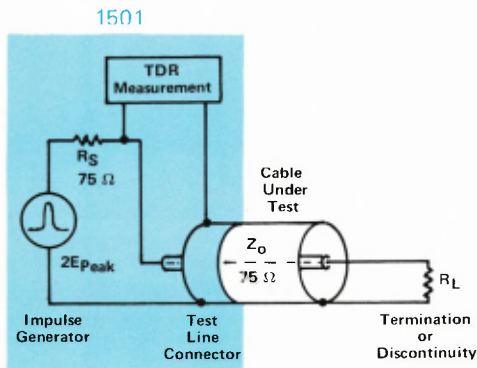

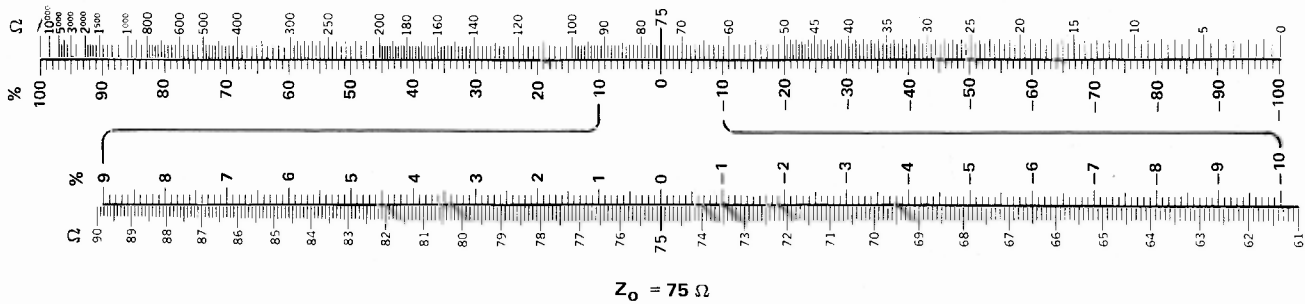

$Z_o = 50 \Omega$

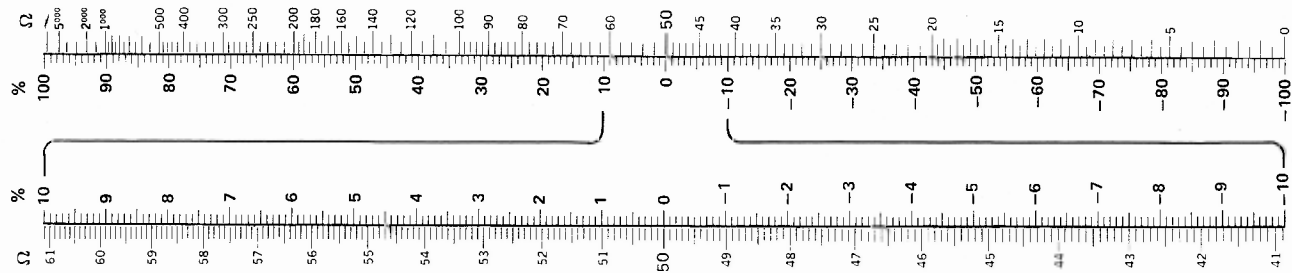

The percent scale of the REFLECTION %/DIV switch is obtained by multiplying the TDR parameter ρ by 100. ρ is defined as the reflected pulse amplitude divided by the incident pulse amplitude.

$$\rho = \frac{E_{\text{reflected}}}{E_{\text{incident}}}$$

Since ρ is dependent on the characteristic impedance of the cable under test, Z_0 and the load on the cable (or the impedance of the discontinuity), R_L , ρ can also be defined as follows:

$$\rho = \frac{R_L - Z_0}{R_L + Z_0}$$

The preceding relationship was used to make the charts on page 28.

Percent or ρ are time-domain parameters. The absolute values of these parameters can be related to frequency-domain parameters VSWR (voltage standing wave ratio) and return loss. The following charts allow the absolute value of percent to be converted to VSWR or return loss.

FREQUENCY DOMAIN CONVERSIONS



Single Resistive Discontinuity Only



Return Loss (Impulse Only)

Transmission line losses due to centerconductor series resistance affect the measurements made with the 1501, especially if the impulse test signal is used. Centerconductor series resistance is made up of two components, low frequency or DC series resistance and high frequency or "skin effect" series resistance.

DC series resistance affects measurements made on long or low quality cables. When the step test signal is used, the DC series resistance, if of sufficient magnitude, will cause the display between the top of the incident step and the beginning of the reflected step to be sloped. This slope can cause problems in determining the location of the discontinuity, but it will not affect the final amplitude of the reflected step. When the impulse is used, however, the DC series resistance will reduce the amplitude of the reflected impulse, making the impedance measurement inaccurate.

"Skin effect" series resistance affects the risetime of the step or impulse. Again, the final reflected step amplitude is not affected, but the amplitude of the reflected impulse is.

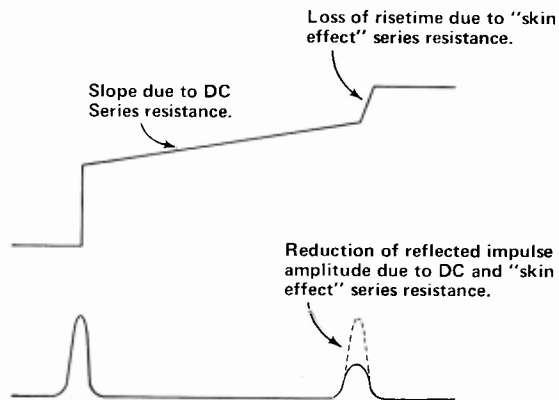

In general, the impedance of a discontinuity can only be approximated using the impulse test signal. The impulse test signal is very useful, however, for locating discontinuities in cables that have a DC voltage or a signal on them at the time of a 1501 measurement.

SPECIFICATION

Test Signals

MODES: Step or impulse.

AMPLITUDE: The step amplitude is nominally 1 volt; the impulse amplitude is nominally 10 volts.

STEP OR IMPULSE RISETIME: 1.3 nanoseconds or less (measured by the 1501).

IMPULSE WIDTH: 1.3 nanoseconds or less (measured by the 1501 at the 50% amplitude level).

ABERRATIONS:

For a step test signal applied to a 75 ohm cable, the aberrations are within +5%, -5%, the total not to exceed 8% peak to peak of the incident step amplitude for the first 10 feet following the step rise; thereafter, the

aberrations are within +2%, -2%, the total not to exceed 4% peak to peak. Into a 50 ohm cable, there is an additional aberration of no greater than +30% over the first 1 foot; thereafter, the aberrations are the same as for a 75 ohm cable.

For an impulse test signal applied to a 75 ohm cable, the aberrations following the impulse are within +5%, -5% the total not to exceed 8% peak to peak of the incident pulse amplitude for the first 10 feet; thereafter, the aberrations are within +2%, -2%, the total not to exceed 4% peak to peak. Into a 50 ohm cable, there is an additional aberration of within +10%, -20%, for the first 1 foot; thereafter, the aberrations are the same as for a 75 ohm cable.

SOURCE RESISTANCE: The source resistance of the test signal generator can be set for either 75 ohms or 50 ohms.

Pulse Amplitude Measurement Capability

REFLECTION %/DIV SWITCH RANGE: The settings of the REFLECTION %/DIV switch are from .5% to 50% in a 1-2-5 sequence.

ACCURACY: The reflected pulse amplitude can be measured to within 3%.

DISPLAY OFFSET RANGE: The DISPLAY OFFSET control allows any portion of a pulse to be displayed on a chart recorder graph or on an oscilloscope CRT.

DISPLAYED NOISE: The displayed noise (measured tangentially) is less than 1 division when the REFLECTION %/DIV switch is set to 1% and the TEST LINE connector is properly terminated. With the NOISE FILTER or CHART POWER pushbutton in, the displayed noise is less than 0.2 division.

TEST LINE CONNECTOR COUPLING: The TEST LINE connector is DC coupled when the cable under test has

less than ± 5 volts on it. When there is more than ± 5 volts on the cable under test, the connector is automatically AC coupled.

TEST LINE CONNECTOR MAXIMUM INPUT VOLTAGE: The maximum voltage that can be applied to the TEST LINE connector without damaging the 1501 circuitry is ± 100 volts (DC plus peak AC) at a maximum frequency of 440 hertz.

VERTICAL OUTPUT SIGNAL: The vertical signal applied to the chart recorder appears at the VERT OUT connector. When this signal is applied to an oscilloscope, the oscilloscope vertical deflection factor should be 200 mV/division for the oscilloscope display to coincide with the 1501 REFLECTION %/DIV switch.

VERT OUT CONNECTOR SOURCE RESISTANCE: 10 kilohms.

Distance Measurement Capability

FEET/DIV or METERS/DIV RANGE: The settings of the RANGE switch are from 2 feet/division to 500 feet/division (.5 meter/division to 200 meters/division) in a 2-5 sequence.

START POINT CONTROL RANGE: The range of the START POINT control is from 0 to 500 feet (100 meters) or from 0 to 5000 feet (1000 meters) depending on the setting of the RANGE switch.

ACCURACY:

The distance from the 1501 to a discontinuity in the cable under test can be measured to within 3%.

Using the START POINT control, a discontinuity can be

located to within 2% of the dial setting \pm one units digit.

CABLE SWITCH SETTINGS: The SOLID POLY position of the CABLE switch sets the 1501 to measure cables with a propagation velocity of 65.9% C (where C is the speed of light); the FOAM (.81) position sets the 1501 for a V_p of 81% C; and the OTHER position allows the V_p to be adjusted between 60% C and 100% C.

HORIZONTAL OUTPUT SIGNAL: A 0 volt to +5 volts ramp appears at both the HORIZ OUT and SWEEP VOLTAGE connectors. If the HORIZ OUT signal is applied to an oscilloscope, the oscilloscope horizontal deflection factor should be 500 mV/division for the oscilloscope display to coincide with the 1501 RANGE switch.

Power Requirements

LINE VOLTAGE RANGE: The line voltage may be from 90 to 136 V AC or from 180 to 272 V AC.

LINE FREQUENCY RANGE: 48 hertz to 440 hertz.

EXTERNAL DC VOLTAGE RANGE: External DC voltage may be from +6 volts to +16 volts.

POWER PACK BATTERIES: The power pack contains six, C size NiCd cells which when new and fully charged will provide at least 8 hours of operating time and at least 30 charts. Full charge time of the cells is at least 16 hours.

Chart Recorder

CHART RECORDER CYCLE: The chart recorder can make one graph in approximately 26 seconds.

GRAPH LENGTH: The recorder length of a graph is 25 centimeters; the total length is 32.5 centimeters.

NUMBER OF GRAPHS PER BATTERY CHARGE: The chart recorder can make 30 graphs or more providing the batteries are fully charged to begin with.

EXTERNAL VERTICAL INPUT: A signal from an external source can be applied to the chart recorder through the EXT VERT IN connector. The deflection factor of the chart recorder is 200 mV/division.

ENVIRONMENTAL REQUIREMENTS

TEMPERATURE: The temperature of the ambient operating environment for the 1501 must be between -15°C and $+55^{\circ}\text{C}$ (0°C and $+40^{\circ}\text{C}$ when charging the internal batteries). When not operating, the temperature can be between -40°C and $+60^{\circ}\text{C}$ (with batteries) and -55°C and $+75^{\circ}\text{C}$ (without batteries).

ALTITUDE: The 1501 can be operated at altitudes up to 30,000 feet. (Above 15,000 feet, the maximum ambient temperature decreases by $1^{\circ}\text{C}/1000$ feet.) The maximum non-operating altitude is 50,000 feet.

HUMIDITY: The 1501 can be operated or stored at a relative humidity of up to 95%.

APPENDIX

Connecting the 1501 to Other Oscilloscopes

The following table gives special instructions for connecting the 1501 to other oscilloscopes.

Oscilloscope (or mainframe)	Plug-Ins (if any)		Special Instructions
	Vertical	Horizontal	
211			Connect VERT OUT to the probe using a probe tip to BNC adapter (Tektronix Part No. 013-0084-01). Connect HORIZ OUT to the oscilloscope horizontal input using a BNC to banana plug patch cord (Tektronix Part No. 012-0091-00).
212			Connect HORIZ OUT to Ch 1 and VERT OUT to Ch 2 using probe tip to BNC adapters (see part number above). Set the Sec/Div switch to X-Y.
323 324			See page 10.
326			None.
422			Change R501 from 500 k Ω to 130 k Ω to obtain a 500 mV/division horizontal input deflection factor. Adjust the Time/Div Variable for a 10 division trace.
432 434			The accuracy of the external horizontal input deflection factor is $\pm 20\%$. The horizontal gain adjustment, R817 (internal), can be adjusted to match the horizontal deflection factor to the 1501 output.

APPENDIX (Cont)

Oscilloscope (or mainframe)	Plug-Ins (if any)		Special Instructions
	Vertical	Horizontal	
453A 454A			Connect HORIZ OUT to Ch 1 and VERT OUT to Ch 2. Set the trigger Source for Ch 1; B triggering for Internal Source, DC Coupling; Horizontal Display to X-Y. Set the Ch 1 position control to approximately midrange and use the horizontal position control to position the trace. If the sweep is not 10 divisions, adjust internal adjustment R835 (453A) or R1024 (454A).
465 475 485			Connections are the same as for 453A or 454A. Set the Time/Div switch to X-Y. Ch 1 variable volts/div may be used to adjust the trace length to 10 divisions.
5100 Series	Any Vertical Plug-in	5B10 5B12N	Connect HORIZ OUT to the Ext Input and set the Time/Div switch to .5 V.
		5B13N	Connect HORIZ OUT to the Ext Input. Push the 50 mV Ext button and adjust the Multiplier for a 10 division trace.

APPENDIX (Cont)

Oscilloscope (or mainframe)	Plug-Ins (if any)		Special Instructions
	Vertical	Horizontal	
7000 Series	7A11 7A12 7A13	7B50 7B70	Connect HORIZ OUT to the Ext Horiz Input; press the Display Mode Amplifier pushbutton; press the Ext (7B50) or Ext ÷ 10 (7B70) pushbutton. Adjust the Variable control for 10 division trace.
	7A15AN 7A16A 7A17 7A18N	7B51 7B71 7B92	The 1501 cannot be used with these horizontal plug-ins.
	7A22	7B52 7B53A 7B53AN	Either a dual-trace vertical plug-in or two single-trace vertical plug-ins must be used with these horizontal plug-ins. Set the Time/Div switch to Ampl and set Triggering for Internal Source and DC Coupling. Connect HORIZ OUT to one vertical channel or plug-in and VERT OUT to the other vertical channel or plug-in. If two vertical plug-ins are used, set the mainframe Trigger Source switch for the plug-in HORIZ OUT is connected to. If a dual trace plug-in is used, set the Trigger Source switch on the plug-in for the channel connected to HORIZ OUT. On the plug-in or channel connected to HORIZ OUT, set the Volts/Div and Variable controls for a 10 division trace. The Vertical Position control on this channel or plug-in should be set to mid-range. Use the Horizontal Position control to position the trace.



